

SEEPEX.
An Ingersoll Rand Business

YOUR PUMP SOLUTION **BIOGAS INDUSTRY**



SOPHISTICATED TECHNOLOGY.

MODULAR PUMP SYSTEM

**MARKET-SPECIFIC
PRODUCT GROUPS
WITH HIGH-
PERFORMANCE
RANGES**

CUSTOMER-SPECIFIC SOLUTIONS

- Application-specific solutions
- Innovative designs
- Reduced life cycle costs
- Low energy consumption
- First-class range of services

CONVEYING CAPACITIES

**0.06 L/H TO
500 M³/H
(0.016 USGPH-
2,200 USGPM)**

DIFFERENTIAL PRESSURES

**UP TO 96 BAR
(1400 PSI)**

Climate protection, the increasing scarcity of fossil fuels and rising energy prices are making alternative energy sources more attractive. In renewable energies, biogas plays a special role.

Biogas is produced from renewable energy sources: crops, green waste or food waste and biological residues. Unlike fossil fuels, biogas is CO₂ neutral – the CO₂ absorbed from the atmosphere during plant growth is released again during combustion.

Biogas reduces the volume of solid waste that have to go to landfills. It is also considered the most desirable of all the renewable energy sources, as it supplies power and heat – as well as fuel. According to industry assessments biogas will gain importance as an energy source in the foreseeable future making it vital that equipment used contributes to safe, efficient plant operation, producing the maximum yield to ensure economic success.

SEPEX, as a global specialist in pumping technology, has been addressing these challenges with technically advanced solutions since 1972 – offering optimized solutions for the biogas industry.

SEPEX progressive cavity pumps, macerators and control systems are used in virtually all applications associated with biogas production. They comply with the most stringent, country-specific and international environmental policies providing:

- Removable compression housing ensures quick and easy maintenance
- Highly safe operation
- Ultimate service-friendly design
- Reliability
- Sustainable manufacturing processes
- Comprehensive range of SEPEX services



We are a member of the German
Biogas Association

Reliability is maximized by a comprehensive range of services for all phases of the pump life. This ensures the long-term value of the pump, optimum operation and dramatically reduced life cycle costs.

Operators of biogas plants benefit from the patented SEPEX Smart Conveying Technology (SCT). SCT delivers rapid maintenance and up to 200% increase of rotor and stator life.

With innovative and efficient technologies, optimized pump systems and economic solutions: SEPEX proves itself to be a sustainable partner for the biogas industry.

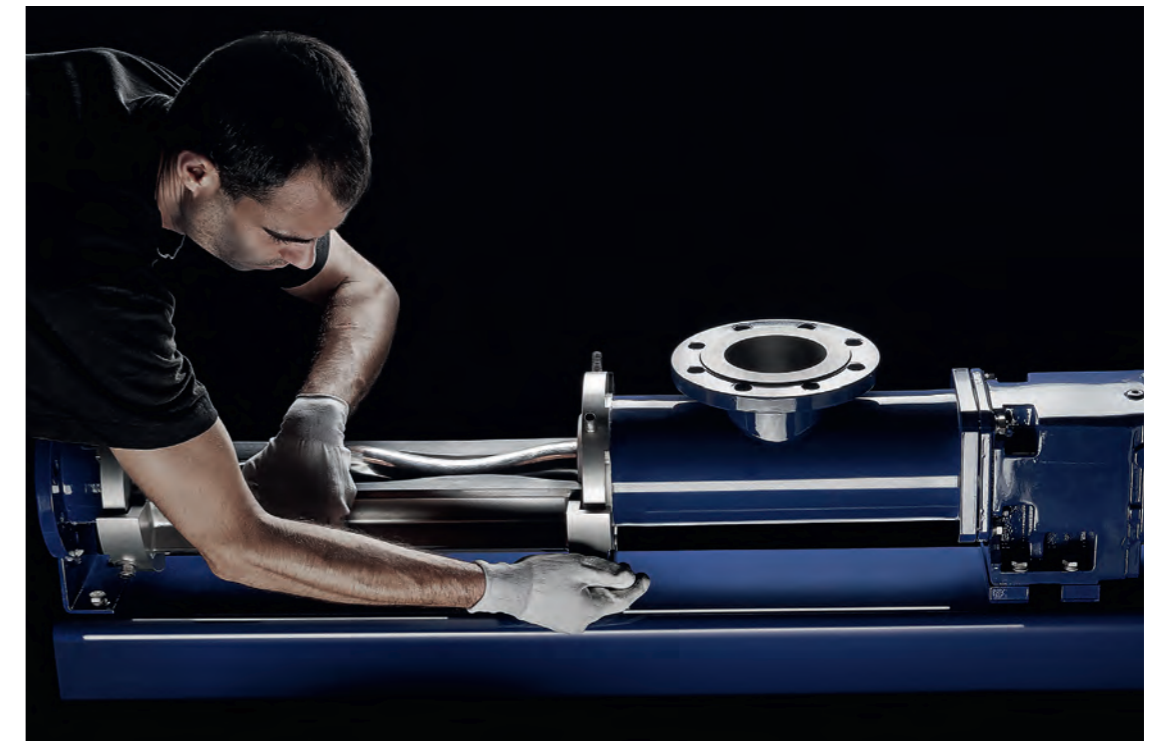

BIOGAS PLANT OPERATIONS.

Biogas is produced through multistage, physical, chemical and biological processes. SEEPEX progressive cavity pumps, macerators and control systems offer pumping solutions that meet the specific requirements of these processes; maximizing gas yield.

BIOGAS PLANT FLOW CHART

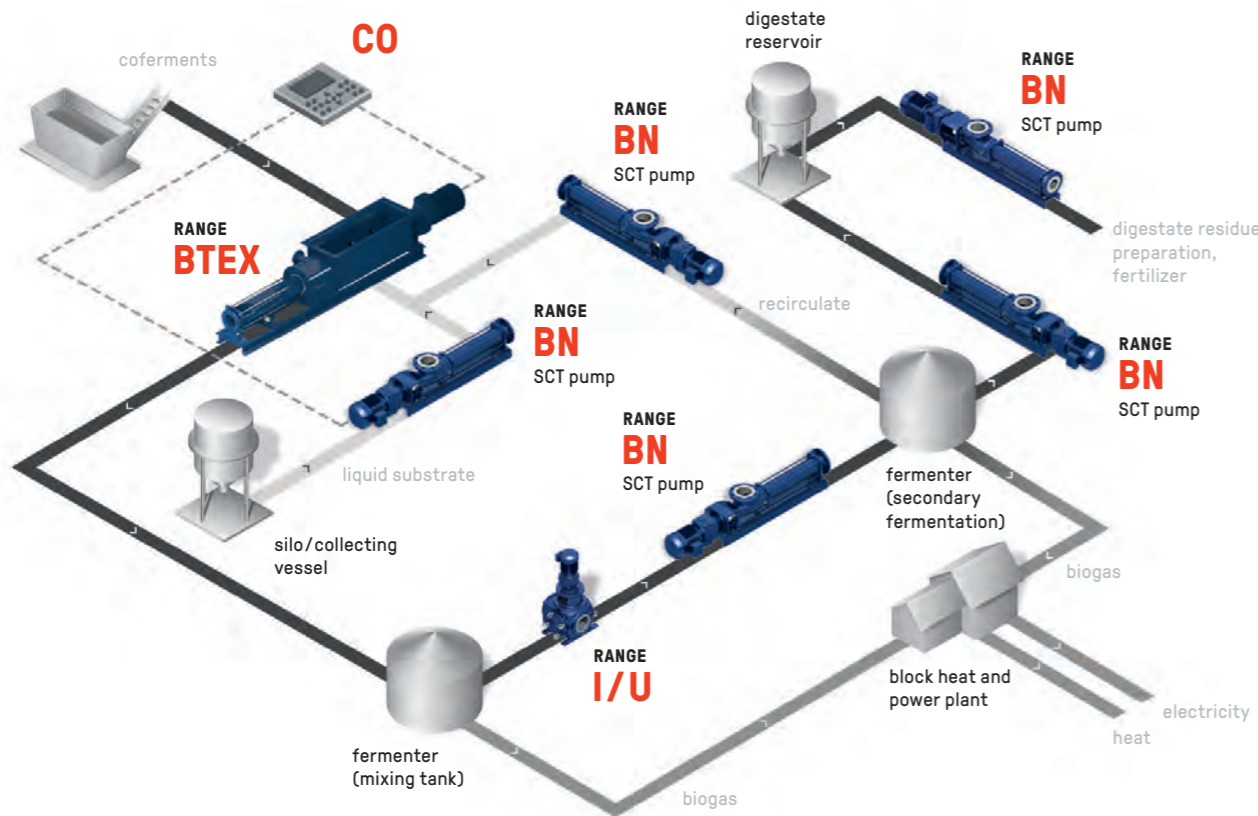

BIOGAS PRODUCTION.

CONVEYED PRODUCT

- Cereal silage
- Digestate
- Fecal sludge
- Food waste – solid and liquid
- Food production by-products
- Biological portion of municipal waste
- Liquid manure
- Solid manure
- Waste fodder

KEY SPECIFICATIONS

MIXING OF LIQUID INTO DS CONTENT FEEDSTOCK

ROBUST EQUIPMENT FOR RELIABLE OPERATION

WITH CONTROL SYSTEMS FOR MAXIMUM GAS YIELD

COST SAVINGS

- Lower investment costs
- Increased productivity
- Reduced maintenance costs

BACKGROUND

In biogas production, various crop based or waste materials are mixed with liquid to form a suitable feedstock for fermentation by the bacteria in digestion tanks. Efficient mixing of variable incoming materials is essential to maximize the gas yield.

TASK

Solid and liquid products like crops, crop silage, manure from farms and feedlots, and recovered waste from municipal wastewater plants and septic tank collection, as well as industrial by-products, food waste and agricultural residues, are thoroughly mixed before being introduced into hydrolysis and fermentation tanks. The incoming products can vary in dry solids (ds) content and viscosity so preparation of a feedstock with a consistent dry solids content is crucial for effective fermentation.

SOLUTION

The SEEPEX bio-substrate mixing system is the ideal solution. It consists of an open hopper pump from product group T, a pump for liquids from product group N in SCT design, along with a BGDC – biogas control system.

BTEX range pumps

BTEX pumps are specifically developed for this application. They feature a robust feed screw and generous hopper with several clean out points. Non-flowable high ds content feedstock is mixed with liquid added by BN range pumps and then transferred to the digesters.

Features:

- Robust design and construction
- Large hopper with clean out ports to remove solid contaminants
- Maximized, elongated pitch of the conveying screw
- Rectangular feed hopper with vertical walls, adaptable length

BGDC control system

On top of special metering, mixing and conveying solutions for biogas plants, SEEPEX also provides the BGDC control system.

Features:

- Flow-controlled introduction of digestate residues in a ratio to provide the correct ds content
- Level control of the pump hopper for optimum mixing of feedstock and liquids
- Optimized mixing for a fast reaction and high gas yield
- Integrated pump protection and monitoring functions

BENEFITS

- Reduced energy consumption
- Efficient plant operations via optimized process control
- Minimal downtime and repair

BIO-SUBSTRATE MIXING FLOW CHART

APPLICATIONS

1. BTEX range pumps ensure a thorough mixing of the fermentation products and subsequently pump them into the fermenter

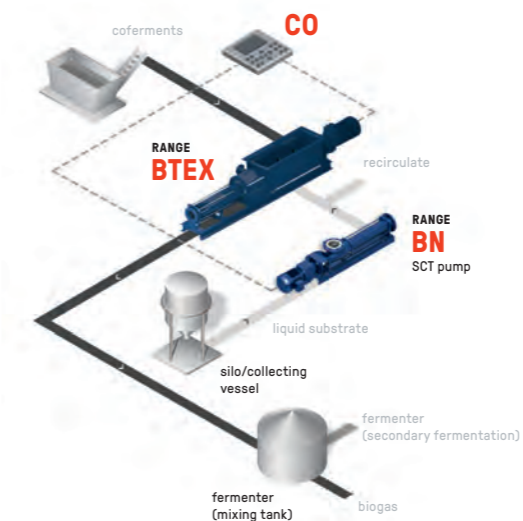

FOOD AND KITCHEN WASTE FOR USE IN BIOGAS GENERATION.

CONVEYED PRODUCT

- Commercial food waste
- Food waste from food and beverage production
- Fats and oils
- Dairy waste, baked goods
- Abattoir waste or animal by-products
- Liquid digestate
- Fryer residue
- Grains and pulp

KEY SPECIFICATIONS

ABILITY TO HANDLE A WIDE VARIETY OF DS CONTENT PRODUCTS

MIXING SOLID AND LIQUIDS TO MAXIMIZE GAS YIELD

RELIABLE EQUIPMENT FOR ABRASIVE APPLICATIONS

COST SAVINGS

- Reduced investment costs
- Maximum gas yield
- Reduced maintenance costs with SCT

BACKGROUND

Food and beverage production generates unavoidable waste and by-products. What used to be fed to animals is now used as an energy source in biogas plants, sometimes producing a complete solution on the food production site where the resultant energy is used. Additionally, high energy value biological residue from household waste is separated out and used for the production of biogas.

TASK

For effective biogas production and to comply with regulations in many countries, the various types of waste must be thoroughly macerated, homogenized and heat treated (if required), before fermentation. Furthermore, the composition of this waste can vary, even in the same biogas plant, from day to day. Thorough mixing with a balancing liquid is therefore essential to produce a homogenous feedstock with consistent solids content.

SOLUTION

SEPEX progressive cavity pumps and macerators have successfully been used in the conversion of food waste into biogas for many years.

Pumps from product group T, combined with BN pumps fitted with SCT provide the ideal combination for mixing variable ds content food waste with liquids to produce the ideal feedstock for maximum gas production. Variable hopper dimensions enables integration with separation equipment to provide an enclosed system.

Macerators and grinders complete the system, reducing the feedstock to the correct particle size for compliance with country wide and global food waste regulations.

Fully integrated control of mixing, the use of boundary layer injection to pump viscous products over long distances and pump protection systems makes the SEPEX solution ideal for both on-site and centralized biogas production plants.

BENEFITS

- Efficient mixing of variable feedstocks for maximum gas production
- Long distance transfer of high ds content feedstock where needed
- Particle size reduction to comply with regulations in an integrated system
- Control and pump protection improves uptime and gas production



SMART CONVEYING TECHNOLOGY.

KEY SPECIFICATIONS

ENERGY SAVINGS COMPARED TO CONVENTIONAL PROGRESSIVE CAVITY PUMPS

ADJUSTMENT TO RESTORE PERFORMANCE EXTENDS STATOR LIFE BY 200%

UP TO 85% REDUCED MAINTENANCE TIME

BACKGROUND

The construction and operation of biogas plants is associated with big investments and high operating costs. The costs of annual maintenance, necessary repairs, downtime and energy use must all be considered.

TASK

It is therefore important to find leverage – to ideally reduce operating costs – and be competitive in the energy marketplace.

SOLUTION

Especially in biogas plants, Smart Conveying Technology (SCT) offers significant advantages over conventional progressive cavity pumps or rotary lobe pumps – for example, in the feeding of products into or circulation of products through fermentation vessels. SCT means quick maintenance, less downtime and dramatically reduced life cycle costs. This SEEPEX innovation has already won several awards.

The design principle of our smart technology: The Smart Stator is divided into two parts, so that maintenance can easily be done in a few simple steps by one person. Additionally, the detachable connection of the Smart Rotor ensures that the rotor can be removed quickly and easily in the case of wear – no special tools are required.

Neither the universal joints, nor the suction or discharge pipe work requires dismantling for maintenance. The result: Maintenance in the shortest possible time resulting in less downtime and increased productivity.

Another design feature is the integrated retensioning device, which allows the clamping between the rotor and the stator to be adjusted for optimum flow – and readjusted when the flow rate reduces due to wear. Readjustment is done in a matter of minutes, returning pump performance to the required level without replacing any components. As such, the service life of both the rotor and the stator is significantly extended without the need for replacement parts, thereby reducing lifecycle costs of the SEEPEX pump.

BENEFITS

- Increased productivity, reduced downtime
- Reduction in maintenance time by up to 85%
- Integrated retensioning device resulting in up to 200% increase of rotor and stator life
- Significantly reduced life cycle costs
- Lighter components allowing faster maintenance and assembly/disassembly with minimal manpower
- Reduced power consumption due to lower energy requirements and higher mechanical efficiencies
- Simple maintenance without the need for special tools
- Less space required for installation and essential maintenance as suction and discharge pipework remain in place
- Environmentally friendly as components can easily be recycled

SMART STATOR

Two, comparatively light, stator halves.

SMART ROTOR

With detachable rotor head connection for fast assembly/disassembly, while leaving the universal joint intact.

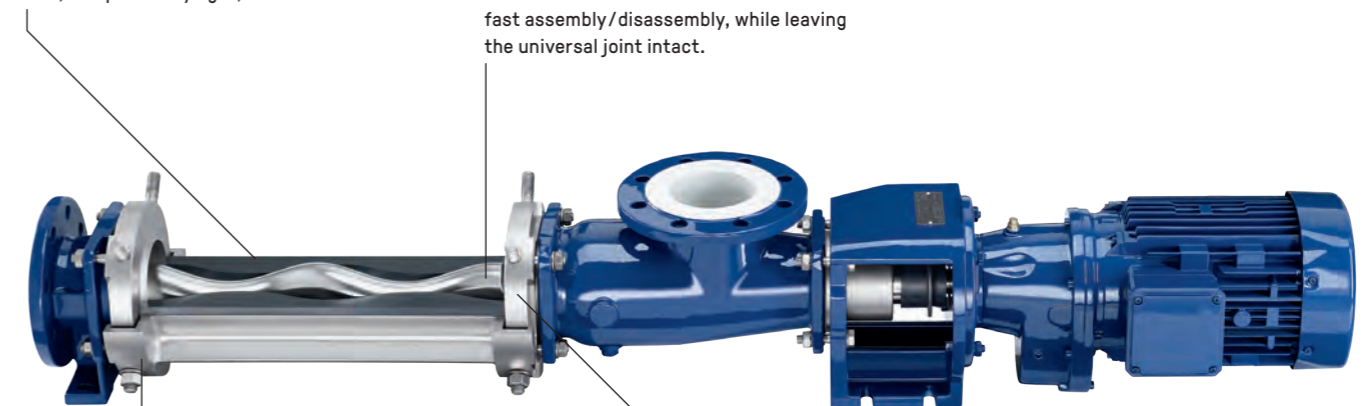

ADJUSTING SEGMENTS

For positioning and axially sealing the stator halves, adjusting the stator clamping and retensioning the stator halves.

SEGMENT RETAINER RINGS

For positioning and radially sealing the stator halves and locating the adjusting segments.

FURTHER APPLICATIONS.

Due to their distinctive design and functionality, SEEPEX progressive cavity pumps, macerators and control systems are ideally suited for use in biogas plants.

They are successfully used in many sectors of the food and beverage industry. SEEPEX solutions are found in the disposal of waste products and in the production processes of the food and beverage industry as well as many other industries.

SEEPEX pumps in the environmental engineering or wastewater industry feature innovative, efficient technologies with fully customizable pumping systems – offering the most economically optimal solutions.

Our conveying technology along with our modular pump system provides the most functionality, highest reliability and lowest life cycle costs for every industry.

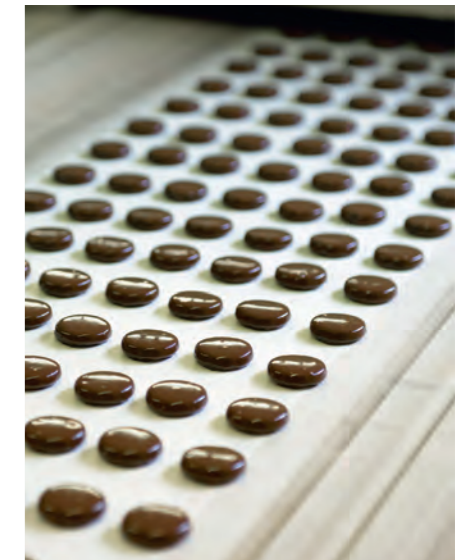

YOUR PUMP SOLUTIONS AT A GLANCE.

BN RANGE

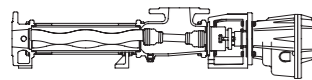

SEEPEX pumps transport thin to highly viscous products with or without solids at low to high temperatures, gently, with minimal pulsation and low shear. They also feature excellent metering accuracy and problem-free pumping of a wide variety of products.

BN range pumps are used in almost all industries. They convey thin to viscous media, with or without solids [containing a dry solids (ds) content of approx. 15%] as well as manure and recirculate.

- Conveying capacity: 30 l/h–500 m³/h (0.13–2,200 USGPM)
- Pressure: up to 48 bar (700 psi)

SCT

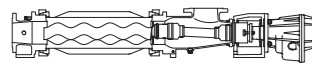

Smart Conveying Technology (SCT) means faster maintenance as the time to replace the rotor and stator can be reduced by 85%. The patented, award winning design of SCT enables the stator to be adjusted to suit the application and to adjust for wear – leading to double the lifetime of the rotor and stator. Downtime and life cycle costs are also reduced.

- Conveying capacity: 130 m³/h (572 USGPM)
- Pressure: up to 8 bar (120 psi)

BTEI RANGE

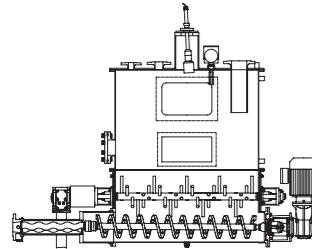

The BTEI range is an ideal choice where an intermediate buffer silo is required. Storage capacity within the pump and hopper of up to 10 m³ is available. The pumps are fully automated with measurement and control devices, guaranteeing consistent product level and continuous feed rates.

- Conveying capacity: 0.5–100 m³/h (2.2–440 USGPM)
- Pressure: up to 36 bar (525 psi)

BTEX RANGE

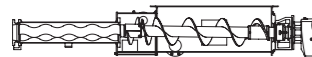

BTEX range pumps have a robust design and reinforced components for abrasive and highly viscous products with potential for hard solids contamination. Liquid addition and mixing of feedstock to a defined ds content is possible and a removable compression housing simplifies maintenance.

- Conveying capacity: 20–80 m³/h (90–350 USGPM)
- Pressure: up to 8 bar (120 psi)

BTHE RANGE

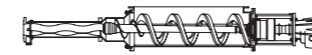

BTHE range pumps feature a feed hopper with vertical hopper walls and a ribbon screw rotating concentrically. This guarantees optimum emptying of the feed hopper and optimized feed of the product into the conveying elements of the pump.

- Conveying capacity: 0.5–130 m³/h (2.2–572 USGPM)
- Pressure: up to 36 bar (525 psi)

BGDC CONTROL

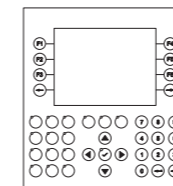

The BGDC control system is an important component of the SEEPEX bio substrate mixing system for the production of biogas. BGDC controls the flow rate of the digestate or liquid feedstock, dosing in the correct ratio to ensure the optimal mixing of liquid and solid substances. All of these process settings can be individually adjusted, saved and accessed at any time.

I RANGE

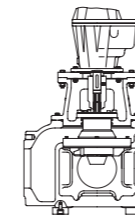

SEEPEX macerators reliably chop solid and fibrous material in pumped media, a necessary step for further degradation such as in the homogenization of the fermentation product in biogas plants. They are available as inline designs with integrated solid separators, as well as a universal version to install on different solids separators each with a direct connection to a SEEPEX pump.

- Flow rate: 2–150 m³/h (8.8–660 USGPM)

SEEPEX.

An Ingersoll Rand Business

SEEPEX GmbH

macxa.com.vn | macxa.vn